

# INSTRUCTION & SAFETY MANUAL

**READ CAREFULLY BEFORE USING THIS FIREARM**

## **HOWA SERIES 1500 SPORTING RIFLES**

**IMPORTANT!** Do not discard!  
Keep this manual with your rifle.  
It should accompany the rifle to  
any new owner.



**Howa**<sup>™</sup>  
*Precision Rifles & Barreled Actions*

## **ABSOLUTELY, POSITIVELY THE FIRST STEP**

The first step in the safe handling of any firearm is to know how to CLEAR it.

The Howa rifle is considered CLEAR when there is no ammunition in the chamber or in the magazine, the bolt is open and the safety is "on".

### **To clear the rifle:**

Point the muzzle in a safe direction. lift the bolt handle and pull the bolt fully to the rear. This should eject any cartridge that may be present in the chamber, but LOOK in the chamber anyway to be sure it is empty. The magazine also is now exposed. If it contains any cartridges, remove them (see page 17). Leave the bolt open and put the safety "on".

Always clear your rifle before handing it to another person. If someone hands a firearm to you, personally determine whether it is clear before any further handling.

Never assume any firearm to be unloaded, and don't accept anyone's assurance. LOOK inside it yourself. When entering or leaving a range or hunting area, or when showing the rifle to others, make sure the bolt is open, the safety is "on", and all ammunition has been removed. That way others can see, without need to operate its mechanism, that the rifle is clear.

## **THESE WARNINGS ARE IMPORTANT**

Firearms, by their nature and intended function, are lethal weapons. By understanding the dangers inherent in the use of any firearm, and by taking proper precautions, you can enjoy complete safety in the use of your firearm. Failure to heed any of these warnings may result in accidental death or serious injury to you or others, as well as severe damage to the firearm or other property.

### **NOT JUST FOR BEGINNERS**

Even if you are familiar with other firearms, don't assume there is no need to study this manual.

Accidents happen to experienced shooters as well as beginners. Most of them could have been avoided if the shooter had read and followed the instructions and observed the basic rules of gun safety.

### **IT'S YOUR RESPONSIBILITY**

Having a firearm in your possession is like being the captain of a ship: it's a serious responsibility, and yours alone. It's up to you to KNOW how to keep and use your firearm safely, and up to you to always TAKE the necessary precautions - all of them. If you fail to do so, and someone gets hurt, the blame rests on you.

Remember: Accidents are rarely the fault of the firearm. A gun is just a machine, with no judgment of its own. It responds to your actions, whether wise or foolish. Of course it has mechanical safety features, but none as effective as the brain of a cautious shooter who never forgets that a moment's carelessness can produce a permanent tragedy.

## **TRAINING IS ESSENTIAL**

The safe handling of firearms requires specialized training, knowledge and discipline. The best way to learn is with supervised instruction, often available from gun shops, gun clubs, state hunter safety programs or police departments. For help in finding a training course, write to the National Rifle Association, 11250 Waples Mill Road, Fairfax, Virginia 22030.

## **GUNS ARE NOT ALL ALIKE**

Many makes and models of firearms might look nearly the same. However, they differ widely in design and operation, and in the location and function of various controls.

Study this manual. Thoroughly educate yourself on the characteristics and operation of this particular firearm before attempting to load it. Do not permit others to have access to your rifle unless they have received proper instruction.

## **SAVE YOUR EYES AND EARS**

Always wear protective shooting glasses and ear plugs or " earmuff " type protectors whenever you are shooting. Your vision and hearing are priceless, and irreplaceable. Always make certain that persons close to you are similarly protected.

Shooting glasses will protect your eyes from burns and abrasions caused by powder gas, metallic particles, burning powder grains, lubricant, and similar debris that can emanate occasionally from any firearm in normal use. If something goes seriously wrong and fragments of cartridge case or firearm are sent flying, shooting glasses can make the difference between future sight and blindness. The best compromise between protection and convenience is offered by high-quality shooting glasses or industrial-grade safety glasses with large-area shatter-resistant polycarbonate lenses at least 2mm thick.

Without ear protection, repeated exposure to shooting noise may lead to cumulative, permanent hearing loss. Many experienced shooters who value their hearing wear both ear plugs AND ear muffs. At a shooting range it is common courtesy not to commence firing until everyone nearby has their eyes and ears covered.

## HOWA MODEL 1500

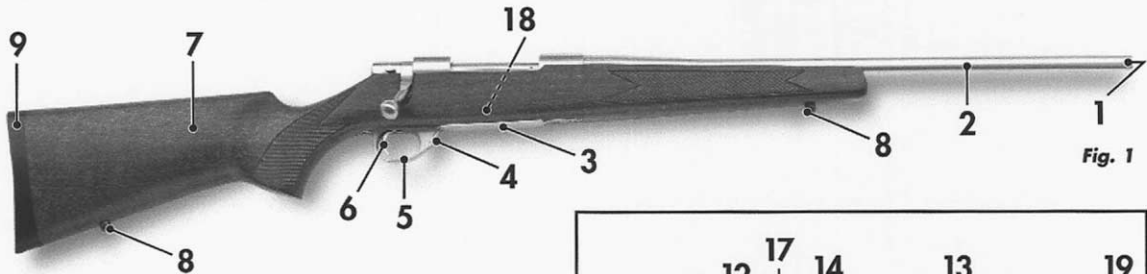

Fig. 1

1. Muzzle of barrel
2. Barrel
3. Floor plate
4. Floor plate catch
5. Trigger guard
6. Trigger
7. Stock
8. Sling swivel stud
9. Butt end of stock
10. Bolt handle
11. Cocking Piece (with firing pin)
12. Bolt sleeve
13. Bolt
14. Receiver
15. Safety

16. Red dot indicator
17. Bolt stop
18. Magazine (inside stock)
19. Chamber end of barrel

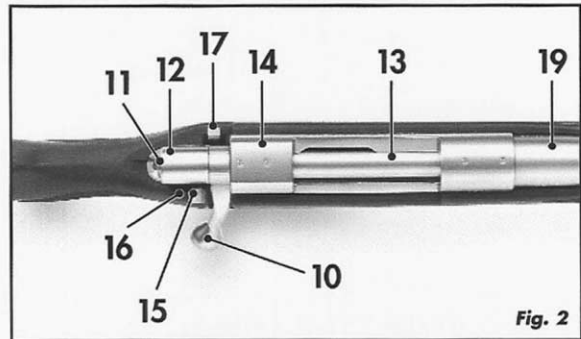

Fig. 2

### Important Terms Which Are Not Individual Parts:

*Bore:* The hole lengthwise through the barrel through which a fired bullet passes.

*Chamber:* The enlarged rear portion of the bore into which a cartridge is seated for firing.

*Muzzle:* The front face of the barrel from which the bullet emerges.

*Magazine:* The space inside the rifle where cartridges are stored to be fed into the chamber. Left, Right, Front, and Rear refer to the rifle as seen by a shooter holding it in the firing position.

## TECHNICAL SPECIFICATIONS

Type and Caliber	Magazine Capacity	Barrel Length	Overall Length	Rate of Twist
<b>Sporting</b>				
.223 Rem	5	22"	42.0"	1:12
.22-250 Rem	5	22"	42.0"	1:14
.243 Win	5	22"	42.0"	1:10
6.5x55	5	22"	42.5"	1:9
.25-06	5	22"	42.5"	1:10
270 Win	5	22"	42.5"	1:10
.30-06	5	22"	42.5"	1:10
.308 Win	5	22"	42.0"	1:12
<b>Varmint</b>				
.223 Ram	5	24"	44.0"	1:12
.22-250 Rem	5	24"	44.0"	1:14
.308 Win	5	24"	44.0"	1:12
<b>Big Game Magnum</b>				
7mm Rem Mag	3	24"	44.5"	1:9.5
.300 Win Mag	3	24"	44.5"	1:10
.338 Win Mag	3	24"	44.5"	1:10
<b>Ultralight</b>				
.243	5	20"	40.0"	1:10
.308	5	20"	40.0"	1:12
.7mm-08	5	20"	40.0"	1:9.5

## SIGHTS

Since most users wish to select a particular telescopic sight and mount combination that satisfies their individual preferences and requirements, your Howa rifle I. delivered from the factory without sights. Mounting holes are factory drilled and tapped to accommodate many popular makes and models of telescopic lights and mounts. Follow the manufacturer's instructions for proper installation and use.

## WARNING!

**LEAD EXPOSURE** Discharging firearms in poorly ventilated areas, cleaning firearms, or handling ammunition may result in exposure to lead and other substances known to the state of California to cause birth defects, reproductive harm, and other serious physical injury. Have adequate ventilation at all times. Wash hands thoroughly after exposure. **SHOOTING OR CLEANING GUNS MAY EXPOSE YOU TO LEAD.**

## TO AVOID A CATASTROPHE

**ALWAYS** keep the muzzle pointed in a safe direction. Never point any gun – loaded or unloaded – at anything you are not willing to see destroyed.

**ALWAYS** assume every gun is loaded until you personally prove otherwise. Don't trust your memory, and never take anyone's word for it.

**ALWAYS** hold your gun so that you can control the direction of the muzzle if you fall or stumble.

**ALWAYS** keep the safety "ON" and your finger outside the trigger guard until the muzzle is pointed at the target and you are ready to fire.

**ALWAYS** keep the gun unloaded until it must be ready for use. If there is no need to load it until later, don't.

**ALWAYS** pay attention where the muzzle is pointing when you (or others nearby) are handling any gun, especially while operating any part of its mechanism. Don't let anyone point the muzzle in an unsafe direction (for example: at you).

**ALWAYS** check for any obstruction in the barrel before loading or if there is any reason to suspect blockage. Bore obstructions are a major source of gun explosions.

**ALWAYS** positively identify your target and be sure there is a safe backstop before you shoot. It's far better than making pathetic excuses afterward.

**ALWAYS** hold your gun so that you can control the direction of the muzzle if you fall or stumble.

**ALWAYS** use high quality ammunition made to American industry standards. Make sure it is clean, dry, in good condition, and of the proper type and caliber for your gun. Defective or improper ammunition is responsible for most malfunctions and blown-up guns.

**NEVER** mix alcohol or drugs with shooting. There is enough danger without the added hazard of fuzzy judgment.

**NEVER** pull a gun toward you by grasping its muzzle end. If the rifle snags on something and fires, the bullet probably won't miss.

**NEVER** attempt to load or unload a gun inside a vehicle or building (except a properly constructed indoor range); there usually is no safe direction to point the muzzle.

**NEVER** shoot at a hard object or at water except under carefully controlled conditions. Bullets can glance off hard materials like rock, glass or steel, or skip off the surface of water, fly in unpredictable directions – and kill.

**NEVER** leave an unattended gun loaded. Guns and ammunition should be stored separately, locked and beyond the reach of children and careless adults.

## AMMUNITION

1. Use only high quality, original factory-manufactured ammunition. Do not use cartridges that are dirty, wet, corroded, bent, or damaged. Use only ammunition of the caliber for which your firearm is chambered. The proper caliber is permanently engraved on your firearm; never attempt to use ammunition of any other caliber.

2. Do not oil cartridges, or spray aerosol lubricants, preservatives or cleaners directly onto cartridges or where excess spray might come into contact with them. Highly penetrative lubricants can migrate inside cartridge cases and contaminate the primer and/or propellant powder. Either a misfire or a failure of the powder to ignite may result. If only the primer ignites, there is danger that the bullet may not exit the barrel, and obstruct the bore.

3. Store ammunition in a cool, dry place, away from sources of heat. Heat shortens the shelf life of ammunition by accelerating the chemical decomposition of primer and propellant.

4. Make a habit of regularly examining your fired cartridge cases, particularly when trying different ammunition. Watch for abnormalities: punctured, loose, or excessively flattened primers; split, deformed or partially separated cases; rough or cratered firing pin indents, torn rims, etc. "Reading" the cases can reveal a lot about the quality of the ammunition and the condition of the rifle, allowing corrective steps to be taken before something ugly happens.

5. Don't mix up ammunition. Keep cartridges in their original box until you are ready to load them. When afield, carry only one caliber of ammunition in your pockets. At the range, put only the ammunition for the firearm you are currently using on the shooting bench. Don't put ammunition of different calibers or loads in the same box or loose in a range bag. It is too easy to pick up and load the wrong cartridge, with potentially disastrous results.

# WARNING!

Excessive pressure in the barrel when a shot is fired can blow up even the strongest firearm, and cause death or serious injury to the shooter or others nearby.

Even at normal firing pressure (often in excess of 50,000 pounds per square inch), if the cartridge case bursts the uncontrolled escape of propellant gas from the barrel into the receiver area can be extremely dangerous. Explosions from excessive pressure or burst cartridge cases are most commonly caused by defective or improper ammunition or by an obstruction in the barrel. (See warnings in following section, "Bore Obstructions".)

**Defective cartridges** may be overloaded or underloaded, incorrectly dimensioned, improperly manufactured or assembled, or assembled from the wrong or faulty components. Defective ammunition also includes cartridges that are dirty, wet, corroded, bent, split, damaged, contaminated with lubricant, or deteriorated from age or poor

storage. Corrosion, dirt or other foreign matter on a cartridge can impede complete locking of the bolt, and in combination with other faults may result in a burst cartridge case; the same is true of a cartridge that is oversized, damaged or deformed. Another defect is a bullet that is loose in the case neck; this condition introduces a high risk of a bore obstruction.

**Improper cartridges** are those of the wrong caliber or loading for normal use in a particular firearm.

**FOR SAFETY, USE ONLY CLEAN, DRY, HIGH QUALITY AMMUNITION IN GOOD CONDITION MANUFACTURED AND ASSEMBLED TO INDUSTRY STANDARDS BY REPUTABLE MANUFACTURERS, AND OF THE CORRECT CALIBER AND LOADING FOR YOUR FIREARM.**



## WARNING ON RELOADED AMMUNITION

The use of reloaded (or "handloaded", "remanufactured", or other non-standard) ammunition is far and away the most common cause of dangerous malfunctions and blown up firearms.

Reloading is a complex science which unfortunately is not as fully understood by many of its practitioners as it deserves to be. It also requires a high order of quality assurance which many have neither the specialized knowledge nor the equipment to establish and maintain.

A reloaded cartridge is no better than the knowledge, skill and care of the person who made it. The process is endless of seemingly minor details that, if not gotten right, can produce a major disaster. A cartridge that is improperly resized, primed, charged or assembled, or made from the wrong, defective or outdated components, can be extremely dangerous in many ways. It can slam-fire, cause a bore obstruction, produce a malfunction that sets the stage for an accidental discharge, inflict progressive damage to the gun, or suddenly blow it up.

Such problems seldom arise from original factory-made ammunition from major manufacturers who have the experience and facilities to produce it correctly. It is much safer to use only original factory-made cartridges, and you are emphatically urged to do so.

Some intrepid souls nonetheless will choose to use reloaded ammunition. They should understand that they are embracing an extra and potentially lethal risk, and must accept full responsibility if injury results.

**HOWA AND LEGACY SPORTS  
INTERNATIONAL WILL ACCEPT NO  
RESPONSIBILITY WHATSOEVER FOR  
ANY PERSONAL INJURY OR DAMAGE  
TO THE RIFLE OR OTHER PROPERTY  
ARISING FROM THE USE OF  
RELOADED AMMUNITION.**

## BORE OBSTRUCTIONS

# WARNING!

Barrel obstructions, especially from a bullet stuck in the bore, are a major cause of firearm explosions and can cause death or serious injury to the shooter or others nearby. Immediately stop shooting and check the barrel for a possible obstruction whenever:

- You have difficulty, or feel unusual resistance, when chambering a cartridge, or
- A shot sounds weak or abnormal, or
- Unburned grains of propellant powder are discovered spilled in the mechanism, or
- You retract the bolt to eject an unFired (or misfired) cartridge from the chamber, but only the cartridge case comes out.

In such instances a bullet may be lodged in the barrel. Firing a subsequent bullet into the obstructed barrel can produce an explosion.

### **An obstruction from a stuck bullet can occur if:**

- The cartridge has been improperly loaded with insufficient or no propellant powder, or the propellant fails for any reason to ignite. (Ignition of the primer alone will push the bullet out of the cartridge case but usually does not generate sufficient energy to drive the bullet out the muzzle), or
- The bullet is not properly seated tightly in the cartridge case. If such a cartridge is extracted from the chamber without being fired, the bullet may be left behind in the bore at the point where the rifling begins. Attempting to chamber another cartridge may push the first bullet ahead into the bore (or telescope the second bullet rearward into its cartridge case), making room for the bolt to close. If this cartridge is then Fired an explosion will almost certainly result.

If you have any reason to suspect that a bullet is obstructing the barrel, immediately unload the firearm and look through the bore. It is not sufficient to merely look in the chamber. A bullet may be lodged some distance down the barrel where it cannot easily be seen.

## **BORE OBSTRUCTIONS (continued)**

If a bullet is in the bore, DO NOT try to shoot it out by using another cartridge, or by blowing it out with a cartridge from which the bullet has been removed, or with a blank cartridge. Unburned powder trapped in the bore behind the stuck bullet can detonate in the confined airspace with devastating results.

Often a bullet lodged in the barrel can be removed by gently tapping it out with a Rat-tipped brass rod that closely fits the bore diameter. Don't use a cleaning rod, as it is likely to bend or deform and become jammed in the bore. Unburned powder and other fouling probably will be left in the bore. It is imperative that the bore, chamber, and receiver be thoroughly cleaned to remove all such residue before shooting is resumed.

If the bullet cannot be readily dislodged, take the firearm and the ammunition to a gunsmith. Do not use any more ammunition from that lot until both have been examined and the cause of the obstruction determined.

Soil, mud, snow, water, ice, vegetation, mudwasp nests, etc. are all dangerous inside a gun barrel. If the muzzle of your rifle comes into contact with the ground, or you have reason to suspect that something has gotten into the barrel, unload the rifle and look through the bore. It's not enough to just look at the muzzle; debris can slide some distance inside where it can't easily be seen. If anything is there, clean it out with a rod. Never attempt to shoot it out; the barrel may burst and you could be seriously hurt.

## USE OF THE SAFETY: TWO POSITION

The safety on the Model 1500 rifle consists of a knurled lever on the right side of the receiver immediately to the rear of the bolt handle. When "on", it locks the trigger. Its purpose is to prevent firing if the trigger is pressed inadvertently. It should not be relied upon to prevent accidental discharge from other causes. See page 13.

**A.** The safety is "on" when the lever (15) is pushed fully rearward, covering the red indicator dot in the stock.

**B.** The safety is "off" when the lever is pushed forward, uncovering the red indicator dot (16).

Do not carry the rifle with a cartridge loaded in the chamber without first placing the safety "on". Keep the safety "on" until you are ready to fire and the rifle is pointed at the target.

Note: The safety can be placed "on" only when the rifle is cocked, i.e., ready to fire (Fig. 4). You can see whether it is cocked from the position of the cocking piece (11). When cocked, the rear of the cocking piece protrudes from the back of the bolt sleeve (12).

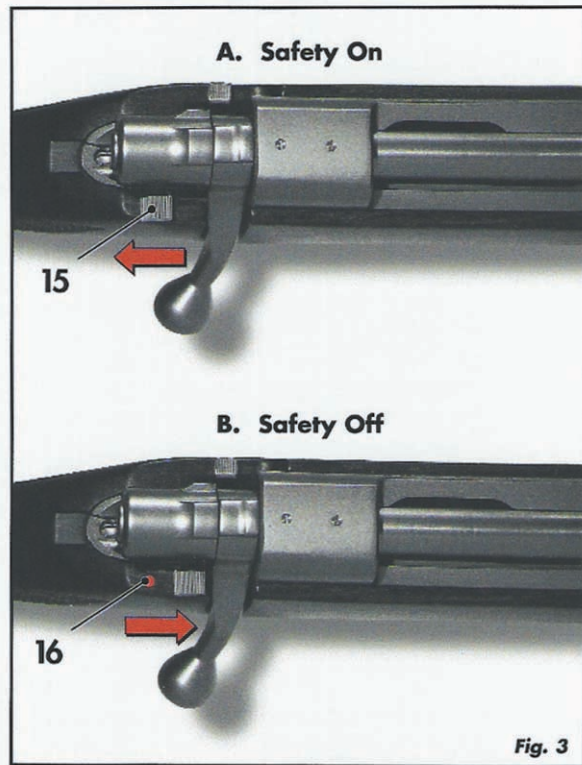

## USE OF THE SAFETY: TWO POSITION (continued)

When the rifle is uncocked, the cocking piece (11) is recessed approximately 3/8th of an inch inside the bolt sleeve (12). In order to place the safety "on" from this position, the rifle must first be cocked by raising the bolt handle fully upward, then closing it again.

The safety operates directly on the trigger mechanism. For this reason, the trigger adjustments have been sealed at the factory. Any attempt to change these adjustments may render the safety inoperative and create a hazardous condition.

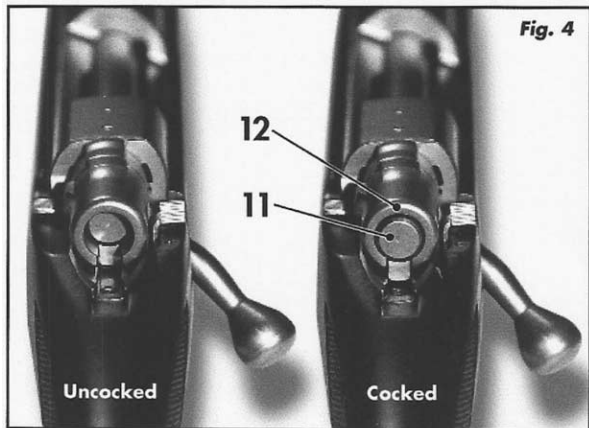

## WARNING!

1. Do not touch the trigger while operating the safety. Pulling the trigger while the safety lever is being pushed "off" will cause the firing pin to be released as soon as the "off" position is reached; if a cartridge is present in the chamber, the rifle will fire.
2. Keep the muzzle pointed in a safe direction when operating the safety. Malfunctions which may cause a gun to fire as the safety is engaged or disengaged are rare but can happen. Even if an accidental firing should occur, nobody will be hurt if you follow this rule.
3. The red indicator dot is for familiarization help only. For safe gun handling, learn by feel the positive "on" and "off" position of the safety lever. When engaging the safety, move the lever fully into the "on" position. Do not rely on merely looking at the dot: the safety might not be fully engaged.

## **USE OF THE SAFETY: TWO POSITION (continued)**

### **3 RULES TO REMEMBER ABOUT A SAFETY**

**1. NEVER TOTALLY DEPEND ON A MECHANICAL SAFETY.** It is not a substitute for proper gun handling. Like all mechanical devices the safety is subject to breakage or malfunction and can be defeated by wear, abuse, dirt, corrosion, incorrect assembly of the firearm, improper adjustment or repair, or lack of maintenance. See Warning on page 12.

**2. NO MECHANICAL SAFETY IS "CHILDPROOF" OR "FOOLPROOF".** No safety ever invented can be relied upon to prevent an accidental shooting by a determined child or a grownup idiot "playing" with a gun. However, you can and should take elementary precautions to secure your firearm from unauthorized handling. See page 27.

**3. TREAT EVERY GUN AS IF YOU EXPECT ITS MECHANICAL SAFETY NOT TO WORK.** You will be astounded at how cautious you become, and how little tolerance you will have for the complacency of others.

It is important to recognize that no firearm can be absolutely safe from firing if it is dropped when a cartridge is present in the chamber. Like any complex tool having small parts, a gun can be damaged or broken, and its safety mechanisms defeated, if it is subjected to sufficient abuse such as being dropped on a hard surface.

**You can largely eliminate the risk of a drop fire by taking the simple precaution of keeping the chamber empty until you are ready to actually shoot.**

If you do drop your firearm, unload it and have it checked by a competent gunsmith to be sure there is no internal damage that would render it unsafe or unreliable.

## **Use of The Safety: Three Position**

The new 3 position safety works the same as the 2 position safety in the first 2 safety positions "ON" and "OFF". In the new 3rd safety position (all the way to the rear), the safety is "ON" and the bolt cannot be opened.

To summarize, the three positions in the new safety are as follows:

- 1.** The safety is "OFF" when the lever (17) is pushed fully forward, uncovering the red indicator dot (18) in the stock.
- 2.** The safety is "ON" when the lever is pushed to the middle position, covering the red indicator dot. The bolt may be opened in this position for safe loading or unloading.
- 3.** The safety is "ON" when the lever is pushed fully rearward, covering the red indicator dot. In this position, the bolt is locked and cannot be opened.

**WARNING: Do not screw in trigger guard when bolt is in gun.**

# WARNING!

1. While loading (and at all times!) make sure the muzzle is pointed in a safe direction!
2. Risk of an accident is greatly increased when any firearm, no matter how safely designed, is carried with the cartridge in the chamber. Unless the firearm must be ready for immediate firing, leave the chamber empty. Load the chamber only when you are ready to actually shoot.
3. Always point the muzzle in a safe direction when manually operating the action to load the first cartridge from the magazine into the chamber. Malfunctions which allow the gun to fire as the bolt is closed without the trigger being pulled are rare but can happen.
4. Never attempt to load or unload any firearm inside a vehicle, building or other confined space (except a properly constructed shooting range).

Enclosed areas frequently offer no completely safe direction to point the firearm; if an accidental discharge occurs, there is great risk of injury or property damage.

5. Before loading, always clean all grease, oil, solvent, etc. from the bore and chamber. When a bullet is fired, an accumulation in the bore or chamber of any lubricant or other incompressible fluid (including, for example, rainwater) can cause a bulge or burst barrel or other damage to the rifle and result in serious injury to the shooter or to others nearby. In addition, any coating of lubricant in the chamber interferes with the adhesion between cartridge case and chamber wall that is necessary for safe firing, and subjects the rifle to stress similar to that imposed by excessive pressure.



## LOADING

Beginning with the rifle empty and uncocked:

**1.** Point the muzzle in a safe direction! Lift the bolt handle and pull the bolt to the rear until it stops. Put the safety "on". Check the chamber to make sure it is empty.

**2.** Press cartridges down into the magazine one at a time as shown in Fig. 5 until the magazine is full (5 cartridges in standard calibers, 3 in magnum calibers, 6 in .223 caliber).

**3.** If you intend to commence shooting immediately, push the bolt back forward and turn the handle down to its original position. In its forward movement, the bolt will pick up the top cartridge in the magazine and feed it into the chamber for firing (Fig. 6). The rifle is ready to fire as soon as the safety is pushed "off".

**4.** If you will not be shooting immediately, minimize any risk of accidental firing by leaving the barrel chamber empty until you are actually prepared to fire. Follow the loading procedure under "closing the bolt without loading the chamber" (Figs. 7 and 8).

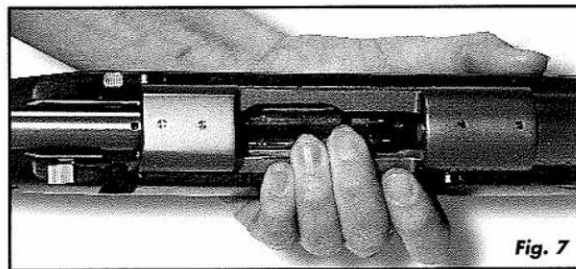
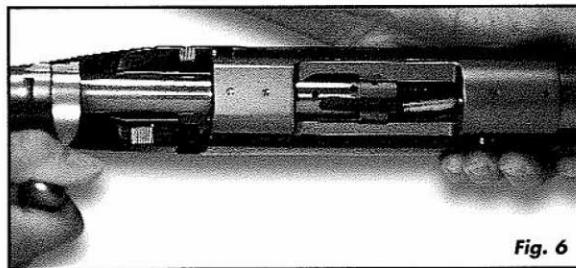
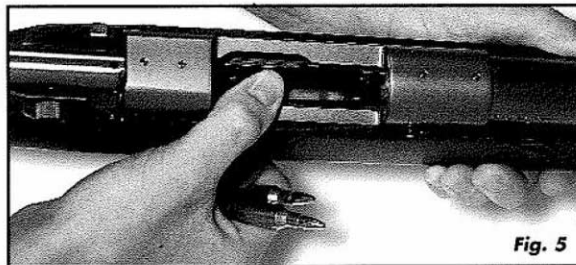

## LOADING

### Closing the bolt without loading the chamber

After loading the magazine but before closing the bolt, depress the column of cartridges in the magazine with your fingers while slowly sliding the bolt about half way forward so that it overrides the top cartridge (Fig. 7). Now, remove your fingers and finish closing the bolt, watching to make sure that no cartridge is pushed into the chamber (Fig. 8). leave the safety "on"!

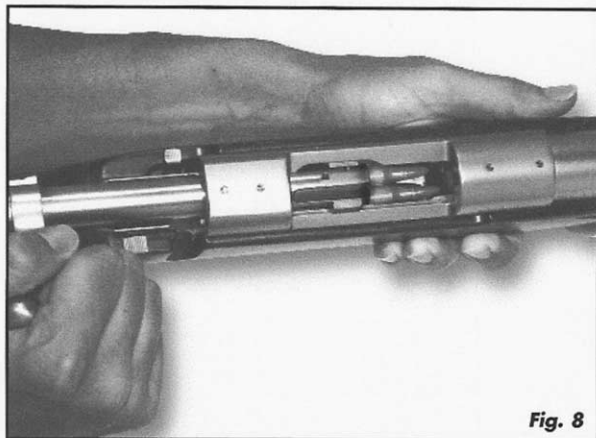

### Loading an extra cartridge

In certain hunting situations you may wish to load the rifle with one cartridge more than the magazine capacity. This is accomplished by inserting an extra cartridge directly into the chamber before closing the bolt. To prevent the bolt from also attempting to chamber the top cartridge in the magazine as the bolt moves forward, depress the column of cartridges in the magazine as shown in Fig. 7 and close the bolt on the extra cartridge. leave the safety "on"!

### Single loading

You may also use the rifle as a single-shot by placing one cartridge at a time directly into the chamber (or into the magazine) and closing the bolt. leave the safety "on"!

## UNLOADING

1. Point the rifle in a safe direction! The safety should be kept "on"!
2. Lift the bolt handle and gently pull the bolt to the rear. This will extract any unfired cartridge present in (j) the chamber. Remove this cartridge from the rifle and leave the bolt open.
3. Empty the magazine from below (Fig. 9). Hold one hand loosely under the floor plate to restrain it, and depress the Floor plate catch 141. The hinged Floor plate will pop open, allowing the cartridges to be dumped into your hand. Look in the magazine and chamber to be sure that all the cartridges have been removed.



## WARNING!

1. Always **LOOK** in the chamber to make sure the cartridge has been extracted and the chamber is empty. It is rare for a cartridge to remain stuck in the chamber, but it can happen.
2. It is recommended that you always empty the magazine by the method described above. Do not empty the magazine by cycling the bolt, since this process involves feeding cartridges into the chamber, and introduces an additional risk of an accidental firing.

## FIRING

With a cartridge loaded in the barrel chamber and the safety "on": Point the rifle at the target, push the safety "off", take aim, and fire by squeezing the trigger.

To fire the next shot, open the bolt and pull it smartly to the rear. This cocks the firing mechanism and ejects the spent cartridge case from the previous shot. Pushing the bolt forward again feeds the next cartridge into the chamber, and turning the bolt handle downward closes the bolt. The rifle is now ready to fire again. This process can be repeated until the rifle is empty. If you wish to temporarily cease firing before the rifle is empty, immediately put the safety "on". "Immediately" means before you turn the muzzle away from the direction of the target.

If you have finished shooting, immediately make the rifle safe by unloading it completely.

Extensive dry firing (snapping the firing mechanism without a cartridge in the chamber) is not recommended as it may result in breakage of the firing pin. After making sure the rifle is empty, the rifle may be uncocked without dry firing by lifting the bolt handle, then pressing and holding the trigger while lowering the bolt handle.

While shooting any firearm, an unfired cartridge or fired cartridge case might become jammed between the bolt and the barrel. Clear the rifle as follows. Keep the muzzle pointed in a safe direction and, if possible, the safety on. Pull the bolt fully rearward. The jammed cartridge can then be shaken out or picked out with your fingers. Discard any cartridge that is dented or that has the bullet shoved back into the cartridge case.

# WARNING!

**1.** Keep the muzzle pointed in a safe direction, the safety "on", and your finger away from the trigger until you are ready to fire.

**2.** Never carry about or leave unattended any firearm which is cocked and ready to fire! When cocked and with the safety off, it can easily fire if the trigger is pressed. An accidental discharge could result if you fall or drop the firearm, or if some external object contacts the trigger.

**3.** If while shooting, your firearm develops any mechanical malfunction or binding, or "spits" powder gas, or if a cartridge primer is punctured or a cartridge case is bulged or ruptured, or if the report on firing does not sound quite right, stop shooting immediately! It may be dangerous to continue. Unload the firearm - do not try "one more shot to see if it does it again". (It probably will, but worse. It is amazing how often serious accidents are preceded by warning signs that are ignored).

Take the firearm and the ammunition to a gunsmith for examination.

**4.** Never uncock the rifle with a cartridge in the chamber. This is an unsafe condition, as the firing pin would then be in direct contact with the primer of the chambered cartridge. An impact on the bolt could then cause the rifle to fire accidentally without the trigger being pulled.

**5.** Do not allow other persons to stand beside you where they might be struck by an ejected cartridge case. The case is hot, and may be ejected with sufficient force to cause a burn or cut or injure an unprotected eye.

## DISASSEMBLY

First make sure the rifle is unloaded. Put safety "on".

### 1. To remove bolt from rifle (Fig. 10):

**A.** With the bolt part way to the rear, depress the bolt stop and withdraw the bolt rearward out of the receiver.

### 2. To remove stock:

**A.** Place firearm on a clean padded surface which allows you to firmly grasp rifle. With a well fitting screwdriver, loosen and remove the takedown screw at the rear of the trigger guard. Next loosen and remove the takedown screw in front of the trigger guard.

**B.** Remove trigger guard and carefully separate stock and action. Remove the magazine box from the receiver.

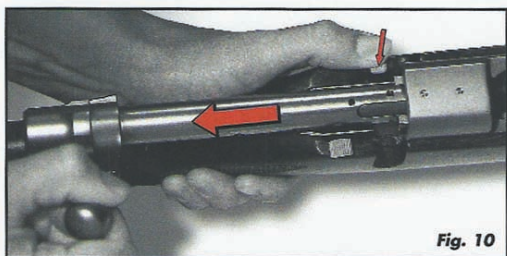

## WARNING!

**1.** Wear safety glasses to prevent eye injury in case any part under spring tension escapes from your grasp.

**2.** Do not tamper with the adjustment screws on the trigger assembly. The screws have been properly set and sealed at the factory. Any attempt to reset the adjustment screws may render the safety inoperative, and result in a hazardous condition. If the seals on these screws have been broken, return the gun immediately to LSI for proper readjustment.

## BOLT DISASSEMBLY & REASSEMBLY

It is seldom necessary to dismantle the bolt, as routine cleaning can be accomplished by brushing and wiping off its exterior. However, should more thorough cleaning be needed, proceed as follows:

**A.** To disassemble: Hold bolt firmly in one hand with the rear of the bolt facing you. With your other hand, rotate the bolt sleeve/~ring pin assembly clockwise about 1/3 turn until it is released from the bolt, and remove it rearward.

**B.** To reassemble (Fig. 11): Align the bolt sleeve/firing pin assembly so that its small lug (A) enters the slot (B) in the bolt hole and slide the bolt sleeve/firing pin assembly into the bolt until it stops. Applying heavy pressure, continue pushing the bolt sleeve/firing pin assembly forward until the bolt sleeve bottoms against the rear face of the bolt. While holding it in firmly, rotate the bolt sleeve/firing pin assembly counter-clockwise about 1/3 turn until a slight click is felt. This click is the nose of the cocking piece (e) engaging its shallow detent notch (D) on the rear face of the bolt (Fig. 12). The firing pin will now be in the cocked position, where it must be in order for the bolt to be correctly reinstalled in the rifle.

**NOTE:** If the bolt sleeve/firing pin assembly is rotated too far, the cocking piece will snap forward into the uncocked position (Fig. 13). Correct this by hooking the cocking piece on the corner of a wooden workbench and drawing it back while simultaneously turning the bolt sleeve clockwise until it engages the detent notch.

Correct assembly is easily checked by looking at the front face of the bolt (Figs. 14 and 15): the tip of the firing pin (E) should be retracted, and not protruding through the firing pin hole (F).

## WARNING!

The bolt sleeve/firing pin assembly is a semi-permanent assembly and should not be disassembled except by a gunsmith. These parts are under heavy spring pressure which could cause injury if improperly disassembled without the use of special tools that are required.

## BOLT DISASSEMBLY

**Fig. 11**

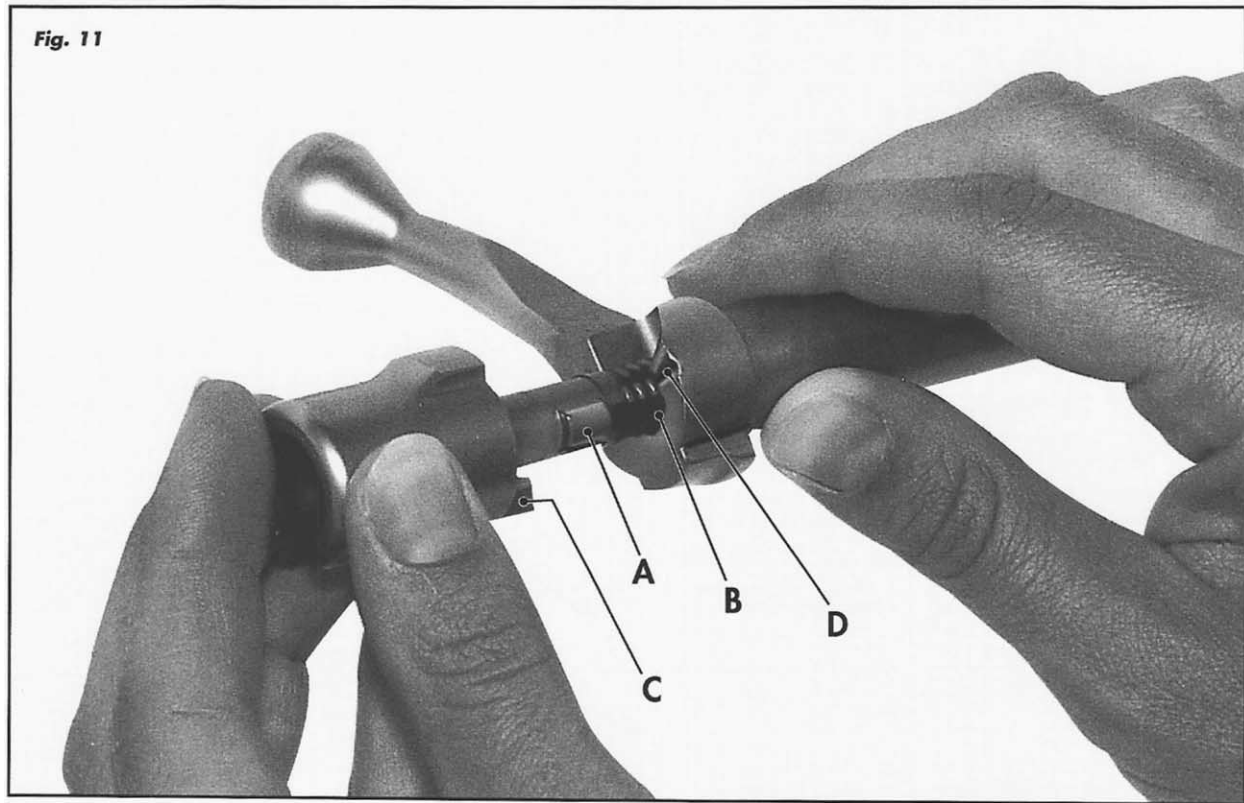



## BOLT DISASSEMBLY

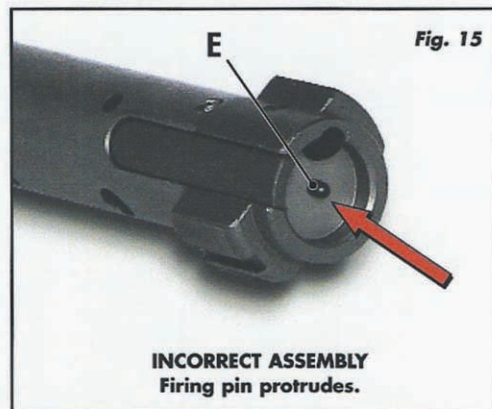
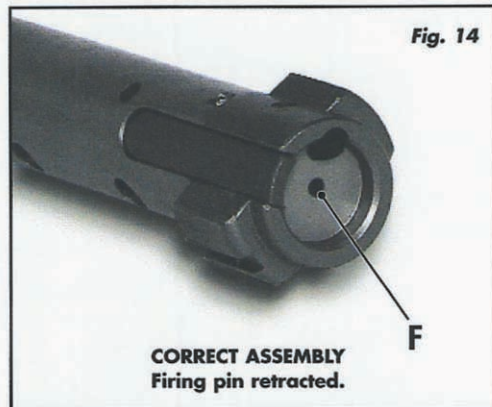
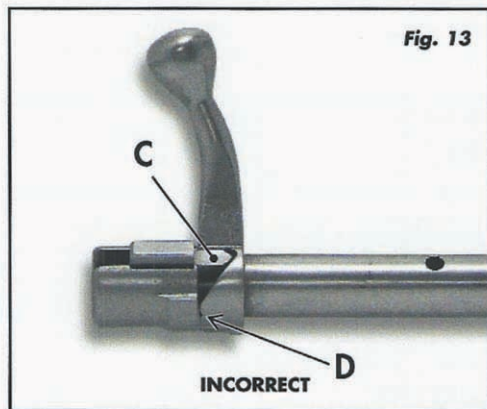
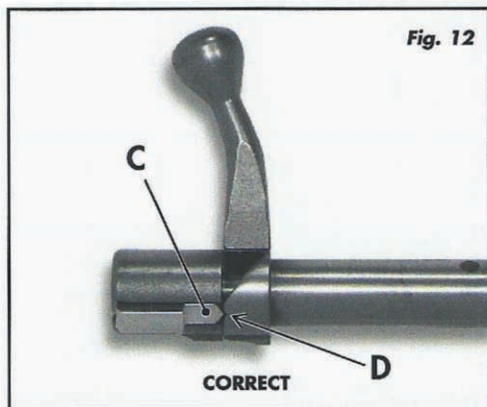

## REASSEMBLY

### 1. To install bolt in rifle

If any cartridge is in the chamber or the magazine, remove it first! Orient the bolt with the handle pointed up and to the right. Align the locking lugs on the bolt with their races in the receiver. Viewed from the rear, the rectangular projection of the cocking piece must be pointing straight down (at 6 o'clock, as shown in Fig. 41). Push the bolt forward gently into the receiver until the bolt stop snaps in place behind it. Close the bolt and turn the handle down to its locked position.

### 2. To replace stock:

Insert magazine box into receiver, open end to the rear and notched end first. Place barreled action assembly carefully into stock. Be certain trigger guard is seated properly in stock. The longer takedown screw goes behind the trigger guard. Tighten the two takedown screws alternately until both are snug, then tighten front screw Firmly; finally, tighten rear screw.

## WARNING!

Any time the bolt is removed and reinstalled, do not load any ammunition into the riRe until the following function check has been performed:

Push the safety "off". Press the trigger. The firing pin should snap forward ("dry-Fire"). Operate the bolt again a full cycle. It should close smoothly and turn down to lock easily, without impediment. If either does not, the bolt may be incorrectly assembled.

Attempting to reinstall an incorrectly assembled bolt with a cartridge in the rifle may, under

unusual conditions, cause the cartridge to fire accidentally as the bolt is being closed, without the trigger being pressed. Serious injury to the shooter could result.

## CLEANING & OILING

First make sure the rifle is unloaded!

Using a cleaning rod, cloth patches and nitro solvent, wipe out the bore until the patches come out clean. Always insert the cleaning rod from the chamber end to prevent wear on the rifling at the muzzle.

Take particular care to thoroughly clean the barrel chamber and the face (i.e., the front) of the bolt. Use a bronze bristle bore brush to remove metal fouling and powder residue from the barrel chamber. A sharpened stick or an old toothbrush can be utilized to clean carbon and other debris from crevasses in the bolt face; especially under the extractor hook. Cotton swabs are useful to clean the recesses in the rear the barrel. Wipe out the bolt raceway inside the receiver.

Pass an oily patch through the clean bore to protect it until the rifle is to be used again. lubricate the bolt with a light film of good gun oil. An oily rag wiped over all external metal surfaces of the rifle will prevent rust from handling.

Before using the rifle again, pass a dry patch through the bore to remove all oil and other residue. look through the bore to be sure it is clear of any obstruction before loading the rifle.

## WARNING!

All firearms require periodic maintenance and inspection which may reveal a need for adjustment or repair.

Have your firearm checked by a competent gunsmith annually even if it seems to be working well, since breakage, improper functioning, undue wear, or corrosion of some components may not be apparent from external examination.

If you notice any mechanical malfunction, do not continue to use the firearm. Unload the firearm and take it to a competent gunsmith immediately. Similarly, if water, sand, or other foreign matter enters the internal mechanism, the firearm should be dismantled for complete and thorough cleaning. Failure to keep your firearm clean and in proper working order can lead to a potentially dangerous condition.

## TRANSPORT AND STORAGE

When transporting your firearm to and from shooting activities, keep it unloaded for your safety and for the safety of others.

When storing your firearm, keep it separated from ammunition, under lock and key and out of the reach of children and other inexperienced or unauthorized persons.

Your stored rifle can be rendered inoperable in many ways. The simplest is to remove the bolt and keep it in a locked drawer. Trigger locks are widely available. Alternatively, with the bolt and floorplate both opened, a simple cable lock (or even a bicycle lock) passed through the magazine well will keep the bolt from being closed. Also, if the bolt is removed an ordinary padlock can be affixed through the rear receiver ring to prevent the bolt from being reinstalled. Wrap the lock with electrical tape to prevent scarring the rifles finish.

## PARTS

It is the responsibility of the purchaser to be absolutely certain that any parts ordered from LSI are of the correct type and are properly fitted and installed by a competent person. This firearm is a precision mechanism and the improper fitting of parts or improper mechanical adjustment may result in a dangerous malfunction, damage to the firearm, and possible serious injury to the shooter or to others. Therefore, the purchaser and/or installer of parts must accept full responsibility for the correct adjustment of and function of the firearm after such installation has been made or attempted.

Even though most gunsmiths have the knowledge, training and ability to make the necessary repairs to your firearm, the skill and workmanship of any particular gunsmith is totally beyond our control. Should your firearm ever require service, we strongly recommend that you return it to LSI.

## PARTS LIST

- 1 (a) Barrel
2. (b) Receiver
3. Bolt stop
4. Bolt stop spring
5. Bolt stop screw
6. Receiver plug screw
- 7A. *Bolt assembly, complete (7-18)*
7. (c) Bolt body
8. Extractor
9. Extractor pin
10. Extractor spring
11. Ejector
12. Ejector spring
13. Ejector pin
- 14 (d) Firing pin
15. Main spring
16. (d) Cocking piece
17. Firing pin retaining pin
18. (c) Bolt sleeve
- 19A. Trigger assembly, complete (19-37)
19. (e) Trigger housing
20. (e) Sear
21. (e) Trigger
22. (e) Trigger pin
23. (e) Retaining ring, trigger pin
24. (e) Trigger adjustment screw, front
25. (e) Trigger spring
26. (e) lock nut
27. (e) Sear pin
28. (e) Trigger adjustment screw, rear
29. (e) Safety plunger
30. (e) Safety plunger spring
31. (e) Block
32. (e) Sear spring
33. (e) Sear stop-pin
34. (e) Safety guide pin
35. (e) Safety
36. (e) Retaining ring, safety guide pin
37. (e) Washer
38. Trigger housing screw
39. Star washer
- 40A. Trigger guard assembly, complete (40-48)
40. Trigger guard
41. Floor plate
42. Floor plate pin
43. Floor plate catch
44. Floor plate catch pin
45. Floor plate catch spring
46. Magazine
47. Magazine follower
48. Magazine spring
49. Rear guard screw
50. Front guard screw
51. Stock (polymer, wood, laminated wood)
52. (f) .223 magazine spacer

### Notes:

- (a) Sold to FFL gunsmiths only, or must be replaced by ISI.
- (b) Not sold separately: available only as part of a barreled action or rifle.
- (c) 7 and 18 are available only as a matched set, or must be matched by ISI.
- (d) 14 and 16 are available only as a matched set, or must be matched by ISI.
- (e) Trigger assembly is factory sealed: individual parts are not sold separately.
- (f) Required for caliber .223 only.

### Ordering Parts:

For information, call: (703) 548.4837,  
ext.13. or fax (703) 549-7826



## SERVICE

To expedite service on any firearm returned to us for adjustment or repair, please follow these instructions:

**1.** Federal law permits you to send a rifle or shotgun to LSI for service via the U.S. Mail (handguns are not mailable except by federal licensees). You also can send it through common carriers such as United Parcel Service (UPS). However, state and local firearms laws vary greatly; you should consult your local prosecuting attorney regarding any restrictive laws in your jurisdiction regarding your receipt of the return shipment.

With the above in mind, it is strongly recommended that any firearm sent to us for repair be sent through a Federally licensed dealer.

**2.** All firearms must be shipped to us prepaid. We will not accept collect shipments

**3.** Be sure to enclose a i.e."letter referencing the serial number and caliber of your firearm. Also state the nature of trouble experienced or work required. Merely stating "defective" or "repair as necessary" is inadequate information. Please be specific and enclose copies of any previous correspondence.

**4.** The firearm must be shipped unloaded. Double-check (and triple-check!) before packing.

**5.** Please do not send telescopic sights, custom stocks, slings, bipods or other accessories with any firearm shipped to us. Remove them before shipment. We cannot be responsible for loss or damage to non-standard items.

## WARNING!

### MODIFICATIONS AND REPAIRS

Do not attempt to make modifications or repairs to your rifle unless you have the necessary knowledge, training, skill and equipment, and are prepared to take full responsibility for the consequences.

Modifications or repairs that are unwisely undertaken or improperly performed can render a rifle unsafe, and lead to someone's death or injury.

Howa and LSI will not be responsible for any malfunction, injury or damage resulting from the alteration or substitution of any part of this rifle or for any repair performed by anyone other than ourselves.

**MOST GUN ACCIDENTS HAPPEN  
BECAUSE THE SHOOTER  
CARELESSLY VIOLATES THE  
SINGLE MOST IMPORTANT RULE  
OF SAFE GUN HANDLING:**

**ALWAYS KEEP THE MUZZLE  
POINTED IN A SAFE DIRECTION!**



## **WHY NO WARRANTY CARD HAS BEEN PACKAGED WITH THIS HOWA RIFLE**

The Magnuson-Moss Act (Public Law 93-637) does not require any manufacturer or seller of a consumer product to give a written warranty. It does provide that if a written warranty is given, it must be designated as "limited" or "full" and sets minimum standards for a "full" warranty. Rather than to attempt to comply with the provisions of the Magnuson-Moss Act and the regulations issued thereunder, Howa and LSI have elected not to provide any written warranty. Thus, NO WRITTEN WARRANTY, EITHER "FULL" OR "LIMITED", IS GIVEN WITH THIS PRODUCT.

Unless excluded in writing, certain implied (unwritten) warranties also arise under state law with respect to sales of consumer goods. Because the extent and interpretation of these implied warranties varies from state to state, HOWA and LSI HEREWITH EXCLUDE ALL SUCH IMPLIED WARRANTIES, INCLUDING BUT NOT LIMITED TO THOSE OF MERCHANTABILITY OR FITNESS FOR A PARTICULAR PURPOSE.

HOWA AND LSI FURTHER EXCLUDE ANY RESPONSIBILITY FOR INCIDENTAL OR CONSEQUENTIAL DAMAGES RESULTING FROM THE USE OF THIS PRODUCT, SUCH AS LOSS OF USE OF PROPERTY, COMMERCIAL LOSS OR LOSS OF EARNINGS OR PROFITS.

Some states restrict the exclusion of implied warranties or of incidental or consequential damages, so the above exclusions may not apply to you.

HOWA and LSI wish nonetheless to assure our customers of our continued interest in providing service to owners of Howa rifles. For Howa's authorized U.S. Service Center, contact LSI at (703) 548-4837, extension 13.